

Instruction Manual

1. Description:

The equipment is used as a termination point for the feeder cable to connect with drop cable in FTTx communication network system. The fiber splicing, splitting, and distribution can be done in this box, and meanwhile it provides solid protection and management for the FTTx network building.

2. Features:

1. Total enclosed structure.
2. Material:PC+ABS, wet-proof, water-proof, dust-proof, anti-aging, protection level up to IP65.
3. Clamping for feeder cable and drop cable, fiber splicing, fixation, storage, distribution...etc all in one.
4. Cable, pigtails, and patch cords are running through their own paths without disturbing each other, micro type PLC splitter installation, easy maintenance.
5. Distribution panel can be flipped up, feeder cable can be placed by expression port, easy for maintenance and installation.
6. Box can be installed by the way of wall-mounted or poled-mounted, suitable for both indoor and outdoor use.

3. Specification:

1. Environmental requirement

Working temperature: $-40^{\circ}\text{C}\sim+85^{\circ}\text{C}$

Relative humidity: $\leq 85\%$ ($+30^{\circ}\text{C}$)

Atmospheric pressure: 70KPa~106Kpa

2. Main technical datasheet

Insertion loss: $\leq 0.15\text{dB}$

UPC return loss: $\geq 50\text{dB}$

APC return loss: $\geq 60\text{dB}$

3. Thunder-proof technical datasheet

The insulation resistance between the grounding device and the metal parts of the box is no less than $2 \times 10^4 \text{M}\Omega/500\text{V}$ (DC); $\text{IR} \geq 2 \times 10^4 \text{M}\Omega/500\text{V}$.

The voltage resistance between the grounding device, and the box and its metal parts is no less than 3000V (DC)/min, no puncture, no flashover; $U \geq 3000\text{V}$

4. Configuration table:

Table 1 Model and configuration

Model	Size (Pic 1) A*B*C (mm)	Max Capacity	Installation Size (Pic 2) D*E*F(mm)	Into the largest cable diameter (mm)	Maximum size of branch hole (mm)	Waterproof SC/AP C adapter
16 CORE	319.3*214*133	48	52*166*166	$\varnothing 8\sim 14$	$\varnothing 16$	16

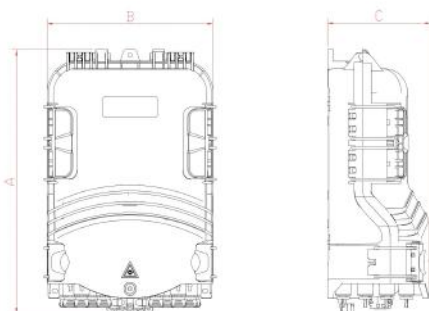

Pic 1 Box Size

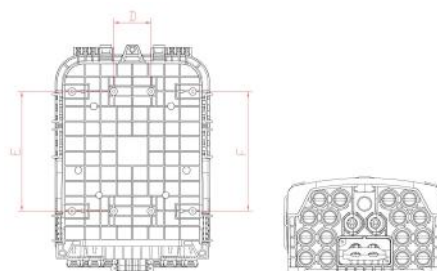

Pic 2 Installation Size

Instruction Manual

5. Product cable ways:

5.1 Product cable ways:

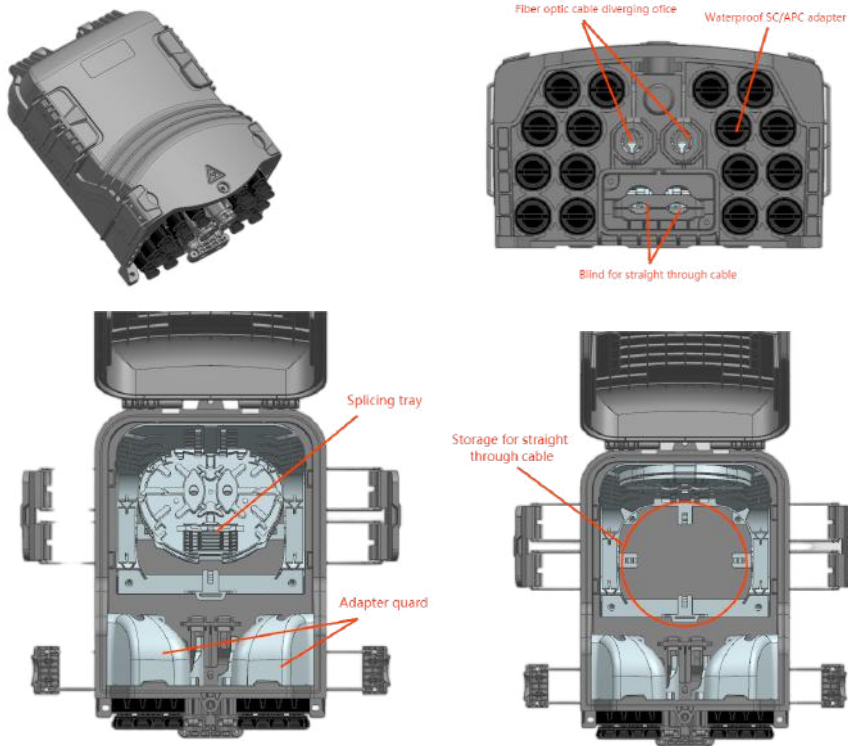

5.2 Fast Plug

Fast installation, fastening, and sealing of straight-through optical cable with the Fast Plug.

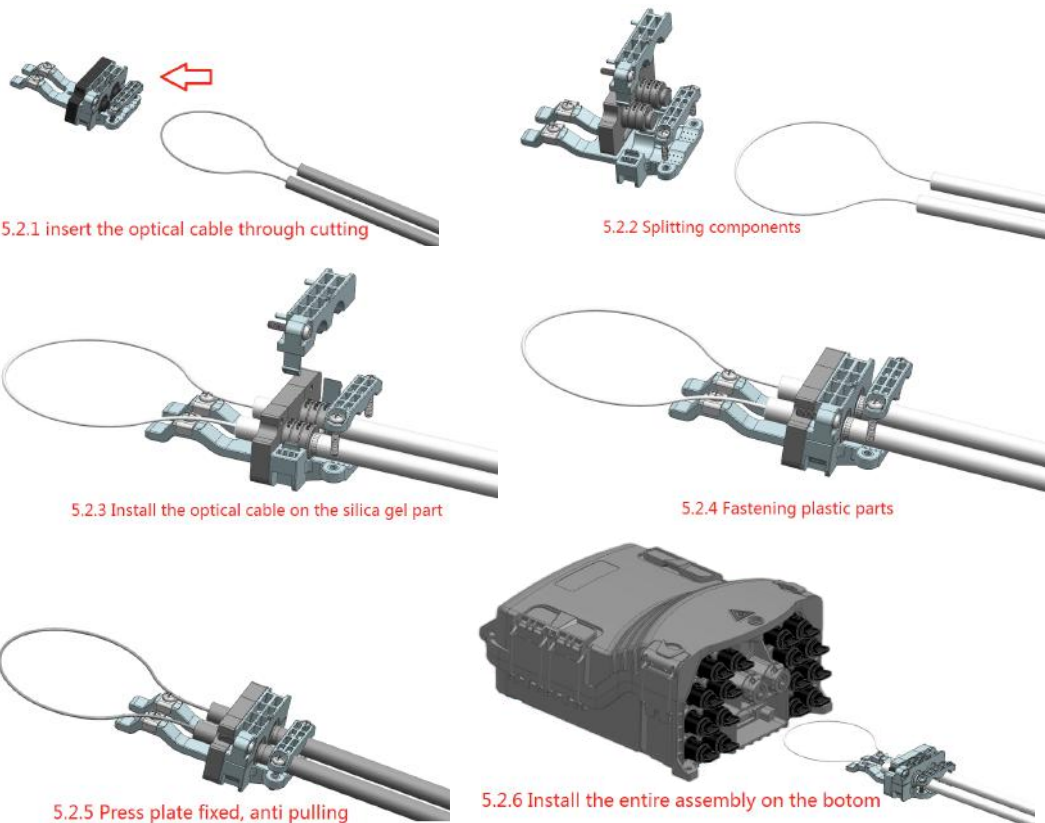

Instruction Manual

5.3 Fiber optic cable bifurcation

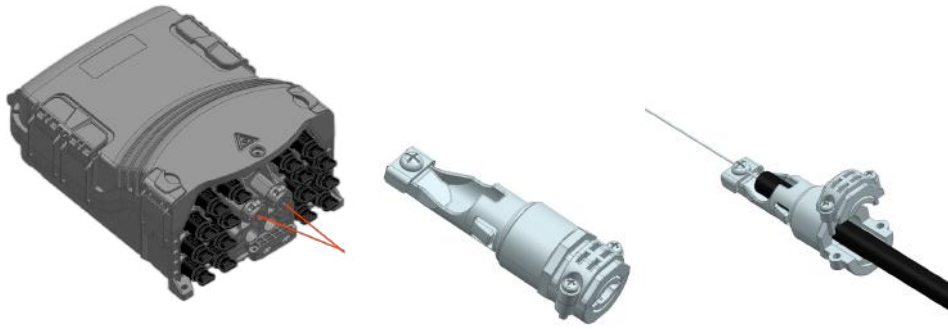

5.4 Product cable ways:

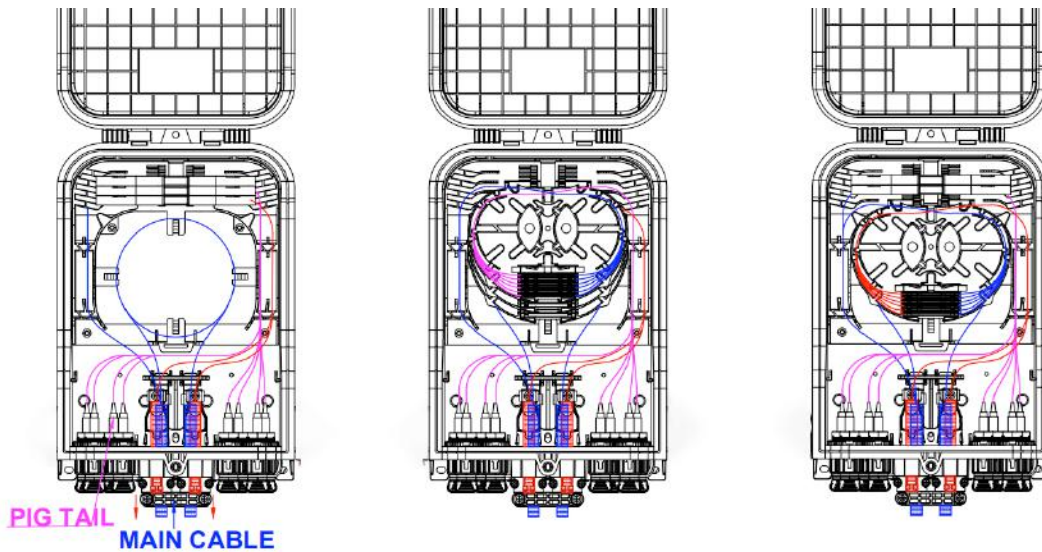

Pic 3 Cable Ways

5.5 Splicing tray

Item	Splicing tray A	Splicing tray B
Dimensions(H x W x D; unit: mm)	134*104*8	134*104*4
Net weight (unit: kg)	0.021	0.015
Picture		
Color	Customizable	Customizable
Material	PC+ABS	PC+ABS
Splicing capacity of a tray(cores)	12, 1 slot for 1/8 PLC	8

6. Installation:

1. Wall-mounted installation

Drill 3 holes into the wall based on the size in table 1, place the expansion bolt $\Phi 7.5*40$, place the box to match up the holes and use bolt to fasten(Pic 4).

2. Pole-mounted installation

Instruction Manual

- Fix 1 set of the pole ring to the telecom pole (Pic 5).
3. The overhead structure
Tie the two installed on the chassis of the overhead hung on the wire, and then bolted, prevent the case fall off.(Pic 6)

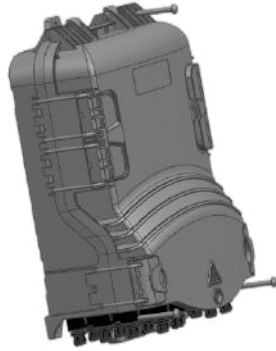

Pic 4 Wall mounted installation

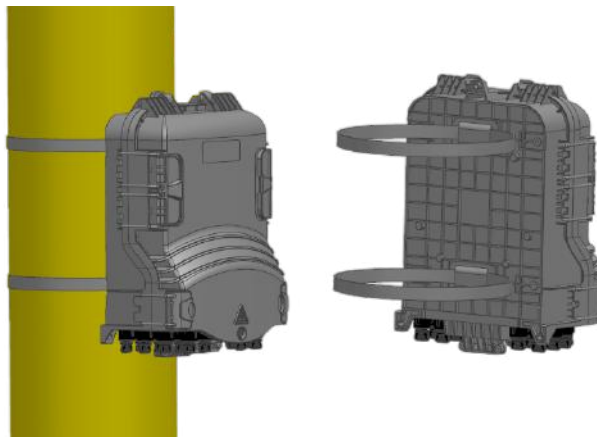

Pic 5 Pole mounted installation

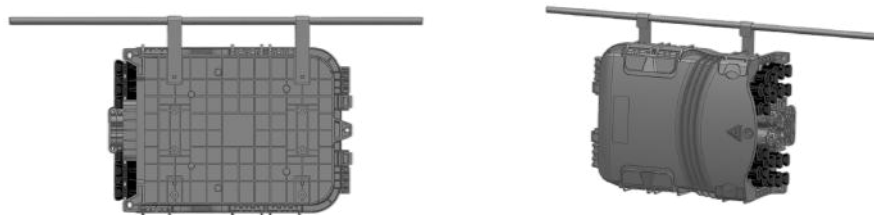

Pic 6 The overhead structure

7. Fiber connector installation:

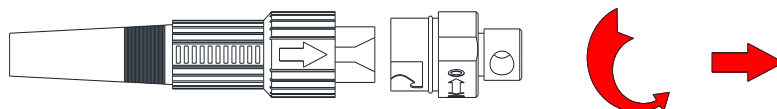

Instruction Manual

Pic 7 Rotate the arrow part of fiber connector counterclockwise and take out the dust cap.

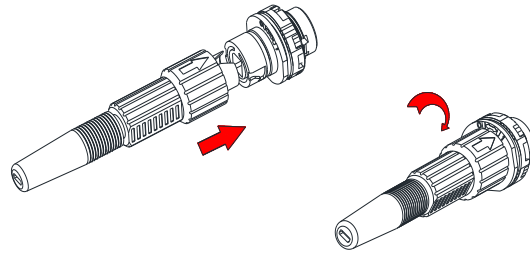

Pic 8 The arrow part of fiber connector is above, insert fiber connector into the socket and then rotate the arrow part clockwise.

8. Accessories:

1. Users' Manual*1
2. Accessories Bag*1
3. Pole Ring*2 (Option)